



## A Phase-Locking Synchronizer for Stabilizing Reflex Klystrons

**M**ICROWAVE signal sources of high frequency-stability and spectral purity are increasingly important to many fields. These include doppler systems, nuclear spectroscopy measurements, spectrum analyzers, as well as telemetry, radio astronomy, and other communications-type work. All of these applications are characterized by the need for good short- and long-term stability as well as low residual f-m noise over a wide spectrum about the operating frequency.

To meet these stability demands, -hp-'s Dymec division has developed a versatile

frequency-stabilizing instrument that gives high stability to typical microwave frequency sources. The instrument is a synchronizer which phase locks a reflex klystron to a desired frequency between 1 and 12.4 gigacycles. The frequency is a harmonic ( $\pm$  the i-f frequency) of a crystal oscillator in the Synchronizer, and the klystron, when so controlled, provides a signal virtually as stable and spectrally pure as the rf crystal reference itself. When thus synchronized, the klystron will have a short-term stability of  $1/10^8$  (averaged over one second) and a long term stability of  $1/10^6$  per week. At the same time residual fm in the klystron due to power supply ripple will be

**SEE ALSO:**  
**A New Klystron Power Supply,** p. 5  
**Black Light Oscilloscope Camera,** p. 8

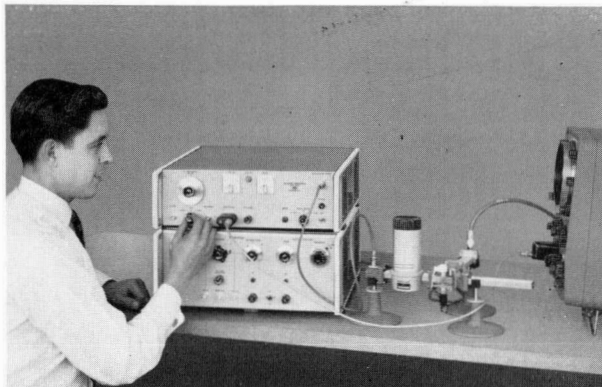
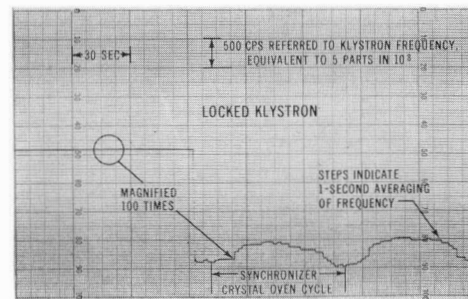
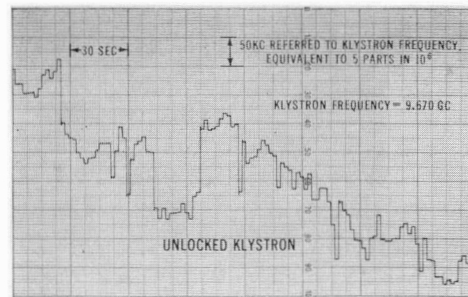

Fig. 1. New Dymec Synchronizer (upper unit) employs phase-lock technique to stabilize reflex klystron oscillators operating in 1-12.4 kilomegacycle range.

Fig. 2 (at right). Measured curves showing operation of new Dymec Synchronizer in stabilizing typical klystron frequency, unstabilized in upper curve. Lower chart shows stabilized klystron frequency has stability of temperature-controlled crystal oscillator in Synchronizer. Final portion of lower chart has  $10^2$  times resolution of upper chart.



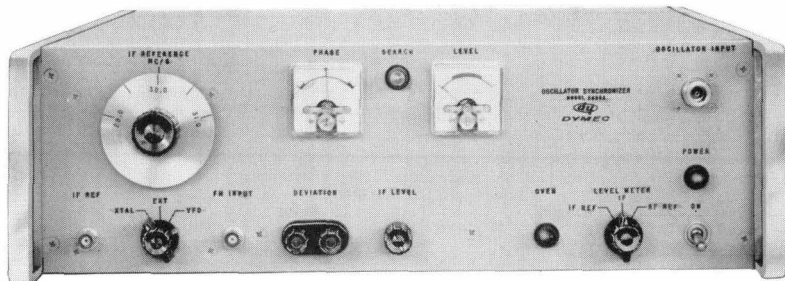

Fig. 3. Dymec DY-2650A Oscillator Synchronizer can be used with most reflex klystrons to achieve high microwave frequency stability. Unit has automatic search and capture capability.

reduced typically by about  $10^5$  times. The synchronized klystron is thus useful as a local oscillator in the most sophisticated receivers such as doppler-tracking receivers, telemetry or radio-astronomy receivers, or as a pump in receivers employing masers as low-noise input amplifiers. The arrangement also permits greater latitude in the selection of a klystron, since more emphasis can be placed on achieving other characteristics such as power output, environmental tolerance, tuning characteristics and reliability.

Besides providing for the particular frequency at which the klystron is to be operated, the Synchronizer produces crystal harmonics at intervals of 200-240 megacycles throughout the 1-12.4 gc range. This enables one Synchronizer to be used over the range of several klystrons to cover the 1-12.4 gc spectrum at more than 100 spot frequencies with a single crystal. The Synchronizer can be used with most klystrons in the medium and lower power ranges requiring up to 2000 vdc on the reflector.\*

Besides fixing and stabilizing the operating frequency of the klystron, the Synchronizer has the additional conveniences that it permits the klystron to be frequency-modulated or to be tuned about the selected frequency. These capabilities permit the introduction of deliberate frequency offsets for doppler applications or precise frequency modu-

lation for scanning or communications applications.

As shown in Fig. 4, the Synchronizer operates in a setup consisting of the klystron to be controlled, a suitable power supply, and a means for sampling the klystron output frequency. The frequency sample is applied to the Synchronizer which operates as an automatic phase-control device to lock the klystron to the designated frequency. An automatic phase-control loop of this sort greatly increases the accuracy and stability over that obtained by afc methods.

#### CIRCUIT ARRANGEMENT

The circuitry of the Synchronizer is basically similar to that of a crystal-controlled double-conversion receiver terminating in a phase comparator, as shown in Fig. 5. The sample of the klystron frequency in the 1-12.4 gc range is connected to the Synchronizer and is heterodyned against a harmonic of the internal rf reference oscillator to generate a difference frequency of about 30 mc.

This frequency is amplified in an if strip to a level suitable for phase comparison with the if reference oscillator. When the if and reference signals are in phase quadrature, zero output voltage is developed by the comparator. When the phase differs from  $90^\circ$ , an error voltage is developed and applied to the klystron reflector in series with the fixed reflector voltage from the power supply. The error voltage readjusts the klystron frequency or phase to compensate for the change. Thus, any tendency for the klystron frequency to change is inhibited and results only in a change of phase between the klystron and the composite reference in the Synchronizer. The phase lag network at the comparator output prevents instability and oscillation in the control loop. The network can be adjusted to optimum for the control sensitivity of the klystron involved. The comparator can develop an error voltage up to  $\pm 20$  volts and can apply it in series with reflector potentials as high as 2000 vdc.

A unique, automatic electronic search circuit is placed at the output of the comparator to increase the capture range of the phase-lock loop to a value close to the lock range. The search circuit also drives a panel light that provides a positive indication of lock. The search circuit and lock indicator make the tuning of the Synchronizer very rapid and easy to handle.

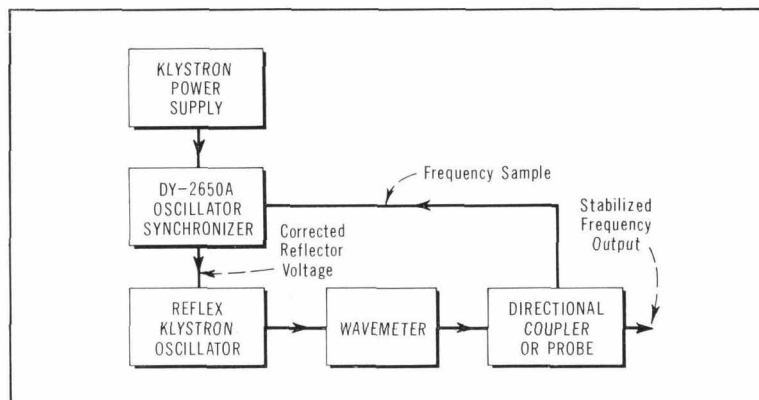

Fig. 4. Typical operational arrangement for Synchronizer.

\*The new -hp- 8614 Signal Generator is also adapted for synchronization over the 0.8-2.4gc range. This Generator also permits pulse modulation of its stabilized carrier by the addition of the -hp- 8714 Modulator unit.

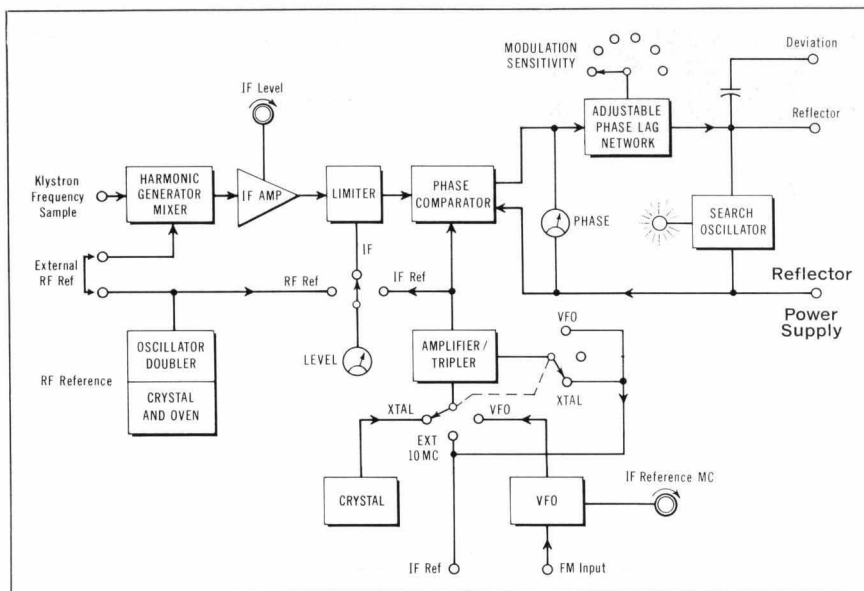

Fig. 5. Basic circuit arrangement of DY-2650A Synchronizer.

The rf reference oscillator is controlled by an oven-mounted crystal operating at a frequency in the 100-120 mc range appropriate for the ultimate klystron frequency. The oscillator is followed by a buffer amplifier and a balanced frequency doubler. The resultant 200-240 mc output is then applied to a diode harmonic generator which generates useful harmonics as high as the 62nd. Any of the harmonics within the tuning range of the klystron can be used as references. The frequencies to which the klystron can be locked are given by:

$$F_k = 2N \cdot F_x \pm F_i$$

where  $F_x = 100 - 120$  mc (as determined by rf crystal)

$F_i = 29 - 31$  mc (as determined by if reference oscillator)

$N =$  Harmonic number (5 through 62). Thus, klystrons tuning over the 8.2-12.4 gc range can be locked to any of 42 frequencies when using a 100-mc crystal in the rf oscillator.

The if reference oscillator in the Synchronizer has three modes to accommodate various uses for the instrument. The oscillator can operate as a crystal-controlled 30-mc oscillator using a built-in crystal, as an amplifier for external reference

signals in the 29-31 mc region, or as a variable frequency oscillator (vfo). In the last mode, the if oscillator circuit can be panel-tuned from 29 to 31 mc and externally frequency-modulated to a maximum deviation of 0.5 mc.

#### KLYSTRON TUNING

Many applications, while requiring a specified operating frequency, still need some tuning flexibility such as for tracking changes in frequency due to drift or doppler offset. The Synchronizer provides for this in including the vfo mode. This allows a klystron to be pulled over a 2 mc range centered on the selected frequency. The ability to f-m the vfo is also useful in applications where programmed frequency shifts or sweeps are required, such as in doppler simulators or spectrum analyzers. The f-m capability can also be put to use to provide a stable f-m test oscillator for narrow band testing of microwave antennas, filters, and other component testing.

#### FREQUENCY/FM MONITORING

While the Synchronizer is intended primarily for klystron stabilization, it can also be used as a frequency stability monitor to check other, less stable, systems. In this role it acts as a fixed-frequency,

double conversion superheterodyne receiver (see Fig. 6).<sup>\*</sup> The second i-f is generated by the beat between the 30 mc i-f reference crystal and the i-f signal. The latter, of course, is created by the beat between the input signal and the  $N^{\text{th}}$  harmonic of the r-f reference oscillator. The second i-f is fed to a frequency meter such as the -hp- Model 500B or a counter such as the -hp- Model 523. These instruments can drive recorders or printers to provide a continuous plot of frequency change vs time. Measurements can be made in this fashion over a range of 2 mc about the specified frequency. The -hp- 500B is particularly useful in providing low frequency f-m information as well, when simultaneous measurement of hum or other spurious modulation is required.

When only f-m monitoring is required, the Synchronizer can be used as a phase-locked frequency discriminator. This is done by connecting the phase comparator output (through the phase-lag network) to the f-m input terminals of the i-f reference channel (vfo mode). This connection permits the vfo to be phase-locked to the i-f signal over its tuning range of  $\pm 1$  mc, thus transferring the signal f-m to the vfo. By observing the control voltage on an oscilloscope, vtvm, or audio amplifier and loudspeaker one can effectively demodulate and monitor the signal f-m.

#### AUTOMATIC SEARCH AND LOCK INDICATOR

Most afc and apc systems are characterized by a narrow capture (pull-in) range and a wide lock (hold-in) range. This occurs because the open-loop bandwidth controls the capture range, while the lock range is limited only by control loop gain and stability considerations. In the Synchronizer the lock range is determined by the maximum phase comparator output swing and the klys-

<sup>\*</sup>When accurate frequency measurements are required over the entire 1-12.4 gc range, the DY-5796 Transfer Oscillator Synchronizer is recommended. See Hewlett-Packard Journal, Vol. 13, No. 3-4, or write for further data.

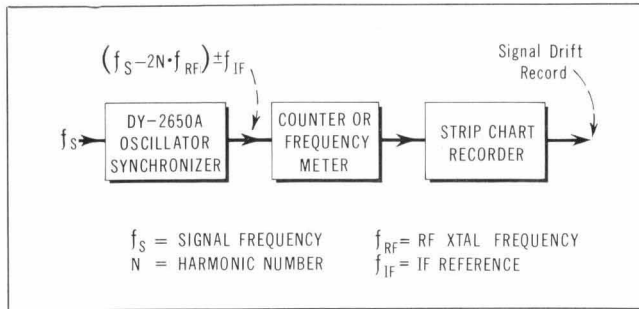

Fig. 6. Equipment arrangement for monitoring stability of microwave frequency sources.

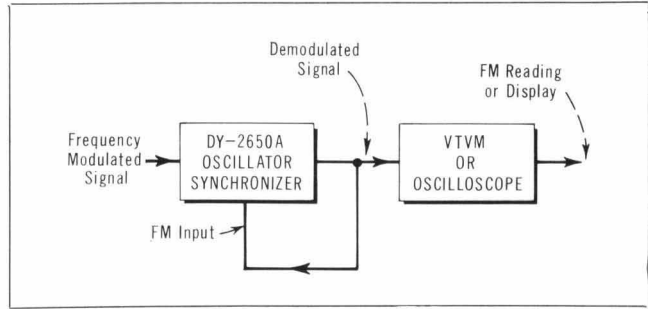

Fig. 7. Equipment arrangement for demodulating and monitoring f-m in microwave sources.

tron used. Since the maximum output is  $\pm 20$  v, the lock range is:

$$f_1 = 40 k_m$$

where  $k_m$  is the klystron modulation sensitivity in mc/volt.

The capture range is given approximately by

$$f_2 = 40 \sqrt{\frac{k_m f_c}{k_\phi}}$$

where  $f_c$  is the loop corner frequency (approx. 0.2 mc) and  $k_\phi$  = the phase comparator sensitivity (20 v/radian).

Thus, for a klystron modulation sensitivity of 1 mc per volt, the lock range approaches 40 mc while the capture range would be only about 4 mc if additional measures were not taken. In practice, this would mean that it would be necessary to tune quite close to the proper frequency to achieve capture. Once locked, though, the klystron can drift quite far without loss of lock. If, however, the system is interrupted when the unlocked klystron frequency is more than  $\pm 2$  mc in error, the system will fall out of lock, necessitating manual retuning to return it to the locked condition.

The Synchronizer eliminates this problem by incorporating the unique electronic search and lock indicator circuit. The search circuit automatically sweeps the klystron over the lock range when out of lock and indicates this search condition by a front panel indicator light.

#### EFFECTIVENESS OF FREQUENCY-STABILIZING TECHNIQUES

The effectiveness of the phase control system as represented by the

new Synchronizer is much superior to previous techniques that have been employed for stabilizing klystrons. One technique that has been used, for example, is the stabilizing cavity or stalo. This is a carefully-designed high-Q cavity which is coupled externally to the klystron output line. Its effectiveness in reducing klystron frequency variations depends on its degree of coupling to the klystron. The tighter the coupling is, the better the stabilization is, but the higher the insertion loss is, too. A typical insertion loss is 10 db or 90% with stabilization ratios from 10 to about 100. High stabilization factors require large, expensive cavities with restricted tuning range and careful mechanical design to reduce temperature drift. The necessarily high insertion loss also reduces the stalo's applications to those situations where the major part of the oscillator power becomes unavailable for practical use because of insertion loss.

Another solution is to use a frequency discriminator as a reference in an automatic frequency control system (afc). Again one can use a microwave cavity as a discriminator, or a heterodyne system terminated in an i-f discriminator transformer. The former method permits continuous tuning over the cavity adjustment range but is limited by the stability of the cavity and its associated microwave diodes and d-c amplifier. The latter method is similar in appearance to the Synchronizer except that an i-f dis-

criminator and d-c amplifier are used in place of the phase comparator and i-f reference channel. The similarity is deceptive, however, because of the great difference in performance between the afc and apc systems.

The basic difference is due to the fact that an afc system cannot eliminate a frequency error between the klystron and its reference but can only reduce it by a factor depending on the gain of the control loop. In an apc system, no steady-state frequency error can exist, since the system works on a difference in phase between klystron and reference signals. Thus, as the unlocked klystron frequency changes, an apc system permits only a phase change, while an afc system permits a reduced frequency change.

Naturally, a continuous frequency drift results in continuous change of phase which is equivalent to a fixed frequency error. A typical example is that of an unlocked klystron drifting at a rate of one megacycle per minute. For a klystron of 1 mc/volt control sensitivity, the Synchronizer would reduce this to a fixed error of approximately  $1 \times 10^{-4}$  cps, an error too small to be measured at microwave frequencies. A typical afc system with a loop gain of 60 db or 1000 would permit the klystron to drift at the rate of  $1 \times 10^3$  cps per minute.

Another factor to be considered in afc systems is the effect of the dc amplifier. Any dc drift in the amplifier is equivalent to a fre-

(Concluded on page 7)



## A NEW WIDE-APPLICATION KLYSTRON POWER SUPPLY

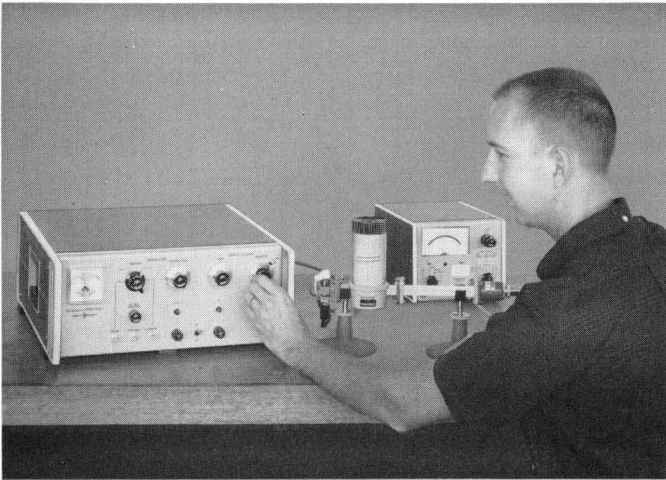

Fig. 1. *New Klystron Power Supply permits high-performance operation of klystrons in exacting, present-day applications.*

DESPITE such recent developments as tunnel-diode and backward wave oscillators, the reflex klystron still enjoys wide use as a source of microwave signals. It supplies pump power for parametric amplifiers, acts as a laboratory signal source, serves as a local oscillator in radar receivers, and finds further use in countless other applications. As a result of this wide use, the requirements placed on klystron power supplies have become increasingly stringent.

The new klystron power supply shown above was developed to be capable of operating nearly any of the reflex klystrons usually used in bench work. Its beam supply (Fig. 3) covers the range from 250 to 800 volts, supplying up to 100 milliamperes beam current under all conditions. The reflector supply ranges from 0 to 800 volts and can be modulated, either by internal square-wave or sawtooth modulators or by an external signal. In addition, the positive swing of square wave modulation is clamped to the selected dc reflector voltage, greatly simplifying SWR measurements. These capabilities enable the 716A to provide power for over 250 different models of reflex klystrons—most of the low and medium power klystrons on the

market today.

In addition to wide capabilities in voltage and current supply, the 716A has low ripple, less than 500 microvolts rms on the reflector and less than 1 millivolt on the beam supply. These features make it useful for low noise applications, such as Doppler radar.

The reflector circuitry, because of the nature of the reflex klystron, is the most critical. The use of high-gain differential stages and careful layout in the reflector supply results in ripple and noise being quite low, less than 500 microvolts rms and typically less than 1 millivolt peak-to-peak. Particular attention was also given to minimizing circuit drift with respect to time and ambient temperature changes. A

typical figure for long-term reflector voltage stability is .02% for 24 hours; a typical reflector supply temperature coefficient is .025% per degree centigrade.

As a convenience to the user, the reflector voltage control is a direct-reading, multiturn dial. Its accuracy is  $\frac{1}{2}\%$  of the dial reading,  $\pm 1$  volt. The equivalent scale length of this control is 3 feet, enabling excellent resolution and repeatability.

### BEAM SUPPLY

The beam supply provides 250 to 800 volts and supplies up to 100 milliamperes beam current over the entire voltage range. Beam current is monitored by a front-panel meter and an overcurrent fuse is also located on the front panel. The ripple and noise of the beam supply, like that of the reflector, is low, less than 1 millivolt rms and typically less than 2 millivolts peak-to-peak. Both turn-on and turn-off transients, which could be harmful to a klystron, have been eliminated. Turn-on transients are avoided by delaying application of the beam voltage until the reflector supply is on. Turn-off transients were eliminated by choosing time constants so that the beam voltage never rises higher than the dial setting when the high voltage is turned off. The beam voltage is controlled by a single turn calibrated dial, the accuracy of this control being  $\pm 2\%$  of dial read-

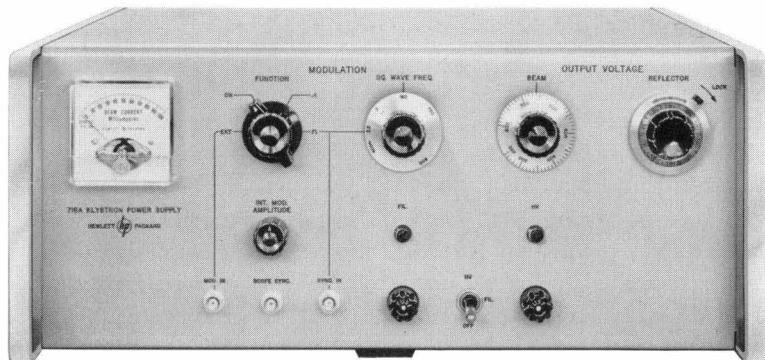

Fig. 2. *Model 716A Klystron Power Supply is designed with very low ripple, clamped square-wave modulation, high-accuracy voltage controls.*

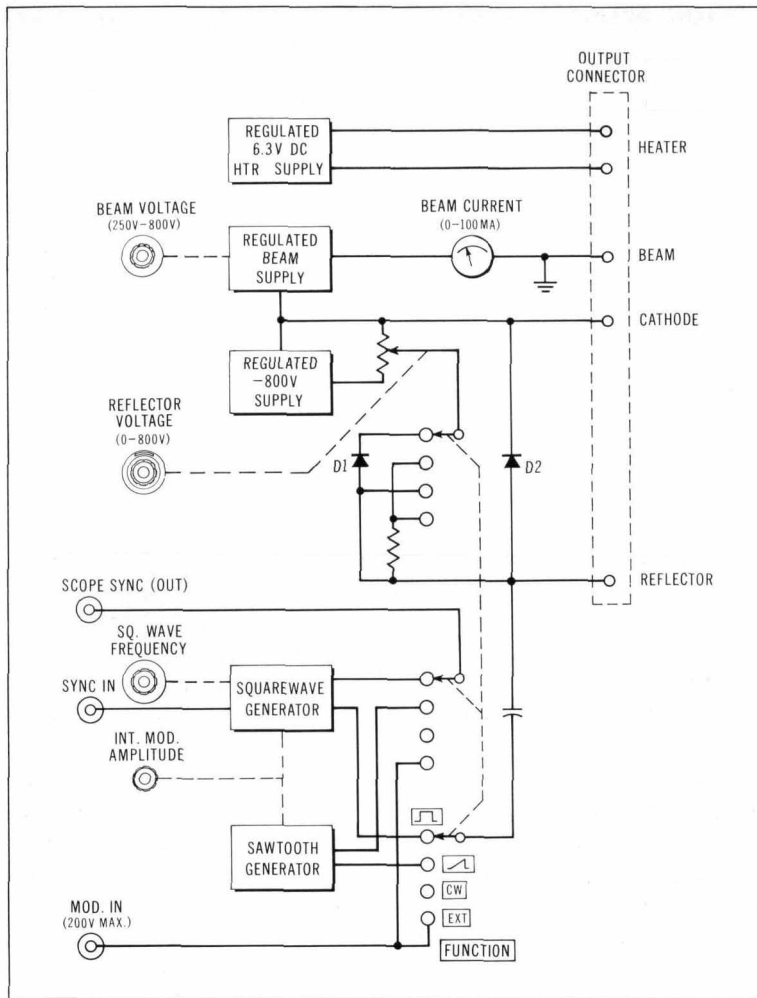

Fig. 3. Circuit arrangement of Model 716A Klystron Power Supply.

ing, an accuracy better than that obtained with most panel meters.

#### REGULATED HEATER SUPPLY

To preserve the good performance of a low-noise klystron, the 716A includes a dc heater supply (isolated from ground). A unique feature of this supply is that it is regulated, keeping the heater voltage constant within 1% of 6.3v for a 10% line voltage change. The regulator also limits the output current by sensing this current, normally passing no more than 3 amperes and passing only about 1 ampere under short circuit conditions. Fig. 4 illustrates this current-limiting characteristic. This provides an advantage to the user in that the inrush current to a cold klystron heater is limited.

#### CLAMPED SQUARE-WAVE MODULATION

The internal modulators have been designed to give the widest range of modulation capability to the reflector voltage. The internal square wave generator operates throughout the range from 400 to 2500 cps, making it usable with virtually all existing standing-wave-ratio meters. Frequency stability is better than 0.1% for 1 hour and in addition, the square wave can be synchronized with an external frequency standard if it is to be used with an extremely narrow bandpass detector. A 1 volt signal for synchronizing an oscilloscope is available at the front panel.

Rise and fall times of the square wave are less than 5 microseconds and are preserved, even with long

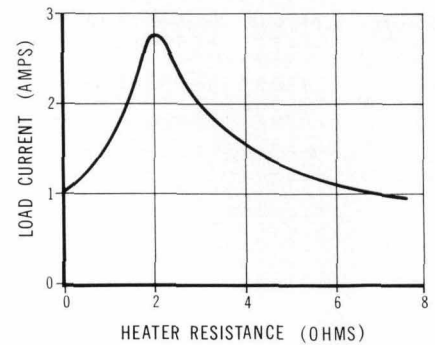

Fig. 4. Maximum current available from klystron heater supply in Model 716A.

lengths of shielded cable to the reflector, by use of a White cathode-follower in the output stage. The amplitude of the square wave is adjustable between 10 and 200 volts and its positive excursions are clamped to the reflector voltage by means of a silicon diode in the output circuit. (D1 in Fig. 3). This arrangement eliminates the need for readjustment of the reflector voltage after the square wave modulation is applied; it also minimizes the possibility of double moding. A second diode (D2) between reflector and cathode outputs prevents the reflector from rising above the cathode potential.

The sawtooth generator, used for frequency modulation of the klystron, consists of a relaxation oscillator with a four-layer diode as the switch. The amplitude is adjustable from 0 to 200v and the frequency, nominally 75 cps, is controlled by an RC network. The frequency can be modified easily by changing the value of the resistance or capacitance. A low-amplitude replica of the modulating waveform is provided at the front panel for synchronizing or driving the horizontal sweep of an oscilloscope. The sawtooth, as well as the external modulation, is AC coupled to the reflector.

The 716A is directly usable with the new Dymec Model DY-2650A Klystron Synchronizer. These two units, used together, give the greatest possible stability and ease of op-

eration. The wide voltage and current capabilities of the 716A and the high stability possible with the use of the -dy- 2650A make the two an ideal combination for stabilizing a klystron.

The 716A is packaged in the -hp- modular cabinet, giving the advantage of compact size, low panel height and ease of rack mounting. Forced air cooling keeps the internal temperature rise to less than 15 degrees Centigrade.

—Robert C. Allan

### SPECIFICATIONS

#### -hp- MODEL 716A KLYSTRON POWER SUPPLY

##### REFLECTOR SUPPLY:

Voltage: 0-800 volts negative with respect to beam.  
Voltage Accuracy:  $\pm 0.5\%$  of dial reading  $\pm 1$  volt.  
Current: High impedance output.  
Ripple: Less than 500 microvolts.  
Line Regulation: Better than 0.05%.

##### BEAM SUPPLY:

Voltage: 250-800 volts negative with respect to chassis ground.  
Voltage Accuracy:  $\pm 2\%$  of dial reading.  
Current: 0-100 ma.  
Ripple: Less than 1 mv.  
Line Regulation: Better than 0.1%.  
Load Regulation: Better than 0.05%.

##### REGULATED DC FILAMENT SUPPLY:

Voltage: 6.3 volts dc, adjustable internally and isolated from ground.  
Current: 0 to 2.0 amperes.  
Ripple: Less than 15mv.  
Line Regulation: Better than 1%.

##### INTERNAL SQUARE WAVE MODULATION:

Frequency: 400 cps to 2.5 kc.  
Amplitude: 10-200 volts, peak-to-peak, positive excursion clamped to reflector voltage.  
Rise Time: 5 microseconds or less.  
Frequency Stability: 0.1% short term.

##### INTERNAL SAWTOOTH MODULATION:

Frequency: 75 cps nominal.  
Amplitude: 0-200 volts p-p, ac coupled to reflector.

##### EXTERNAL MODULATION:

Maximum Input: 200 volts p-p.  
Input Impedance: 500 K, 100 pf nominal.

##### EXTERNAL SYNCHRONIZATION:

Input Voltage: 10 volts peak.  
Input Impedance: 500 K, nominal.

##### OSCILLOSCOPE OUTPUT:

(During Internal Square Wave Modulation)  
Amplitude: 1 volt p-p for oscilloscope synchronization.  
Output Impedance: 600 ohms.  
(During Internal Sawtooth Modulation)  
Amplitude: 10 volts p-p.  
Output Impedance: 50 K ohms.

##### GENERAL:

Meter: 0-100 ma meter monitors beam current.  
Accessory Furnished: 5-conductor cable, 4 feet long.  
Power Requirements: 115 or 230 volts  $\pm 10\%$ , 50 to 60 cps, approximately 200 to 350 watts depending on line voltage and load.  
Weight: Net 45 lb.  
Dimensions: 16 $\frac{3}{4}$  in. wide, 7 $\frac{1}{2}$  in. high (including feet), 18 $\frac{3}{8}$  in. deep overall (cabinet), hardware furnished converts cabinet to 7 in. x 19 in. for rack mounting.  
Price: Model 716A Klystron Power Supply, \$675.00.

Prices f.o.b. factory

Data subject to change without notice

## OSCILLATOR SYNCHRONIZER

(Continued from page 4)

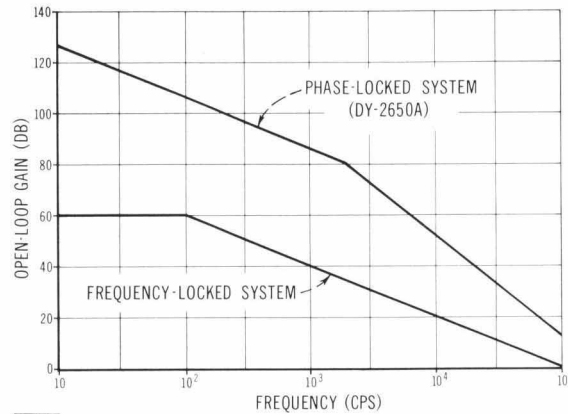

Fig. 8. Comparison of open-loop gain-bandwidth as a function of error frequency for Synchronizer and typical afc system. Continually-increasing low-frequency gain of Synchronizer accounts for its high stabilizing capabilities.

quency error and results in a shift in frequency.

The bandwidth of the dc amplifier usually determines the closed-loop bandwidth of the system. Here a compromise must be arrived at between gain and bandwidth. A typical open loop gain-bandwidth characteristic is shown in Fig. 8 for both the Synchronizer and a typical afc system. It is interesting to note that the afc loop gain continues to increase with decrease in loop frequency. It is this integrating effect

that eliminates steady-state frequency error. The gain is deliberately rolled off at high frequencies by the stabilizing network which can be switched to an optimum value for the klystron being controlled.

### ACKNOWLEDGMENT

The electrical design and development group for the Oscillator Synchronizer included Rudolph F. Pasos, Richard E. Blasing, Lawrence A. Maguire, Kenneth G. Wright, and the undersigned.

—Albert Benjaminson

### SPECIFICATIONS

#### DYMEC MODEL DY-2650A OSCILLATOR SYNCHRONIZER

##### EXTERNAL KLYSTRON DATA:

Input power: -10 dbm sample required at Synchronizer at X-Band, less at lower frequencies. Max. power input: +20 dbm.  
Klystron operating frequency: 1.0 to 12.4 gc.  
Connector: Type N (front panel).

##### RF REFERENCE:

Internal: Provided by quartz crystal, frequency as specified between 100 and 120 mc,  $\pm 0.001\%$ . (See text for formula relating crystal frequency and klystron lock frequencies.)  
External: Within range 200 to 240 mc. Requires 2 v into 50 ohms. Rear panel BNC connector.

##### IF REFERENCE:

Crystal: 3  $\times$  10 mc  $\pm 0.001\%$ .  
VFO: Within range 29 to 31 mc (front panel control).  
External: 29 to 31 mc; 0.5 v into 56 k. (Also 10 and 15 mc nominal, at higher levels). Applied at front panel BNC connector.

##### CONTROL VOLTAGE OUTPUT:

$\pm 20$  v minimum. Floated output is available at rear connector for klystron.

##### DEVIATION OUTPUT:

Front panel binding posts ac-coupled to control voltage output.

##### KLYSTRON CONTROL:

Maximum reflector voltage: 2000 vdc.  
Maximum reflector current: 50  $\mu$ a.  
Control output connector: MS3102R24-27S on rear panel. Reflector power supply may also be applied to this connector. Mating connector furnished.

Power supply connector: MS3102R24-27P on rear panel. Mating connector furnished.

Modulation sensitivity: A 6-position rear panel control provides optimum phase-lag network characteristics for klystron sensitivities from .05 to 4 mc/v. Network can easily be adjusted to suit modulation sensitivities outside this range.

##### STABILITY: (Using internal crystals)

Long term: 1/10<sup>6</sup> per week.  
Short term: 1/10<sup>6</sup> per second. Long and short term stabilities apply for ambient temperatures constant within  $\pm 5^\circ$ C.  
Temperature: 1/10<sup>6</sup> over range 0 to 50°C.

##### FM INPUT:

(Applied via IF Reference Channel)  
Deviation sensitivity: 250 kc/v (into 10 kilohms).

Maximum deviation:  $\pm 500$  kc.

Deviation rate: 0 to 50 kc.

Connector: BNC on front panel.

##### POWER REQUIRED:

115/230 v  $\pm 10\%$ , 50 to 1000 cps; approx. 85 watts.

##### DIMENSIONS:

Instrument is supplied in cabinet; may be rack-mounted by means of side-extensions to panel (furnished).

##### WEIGHT:

Net, 21 lb.; shipping, approx. 35 lb.

##### PANEL FINISH:

Light grey baked enamel. Black-filled engraved titles.

##### ACCESSORIES AVAILABLE:

Additional rf Crystals: Specify frequency required (within range 100 to 120 mc). Price \$65.00 each.

##### ACCESSORIES FURNISHED:

1. Crystal for internal reference oscillator. Frequency as specified (within range 100 to 120 mc).
2. Mating connector for klystron control (MS3106E24-27P) stock no. 2532-0001.
3. Mating connector for klystron power supply (MS3106E24-27S) stock no. 2531-0001.
4. FM Monitor jumper plug (MS3106E24-27S) stock no. 2531-0001 (modified).

##### PRICE:

Model DY-2650A Oscillator Synchronizer, \$1,450.00.

Prices f.o.b. Palo Alto, California  
Data subject to change without notice.

### DYMEC

A Division of Hewlett-Packard Co.  
395 Page Mill Road, Palo Alto, Calif.



## AN OSCILLOSCOPE CAMERA WITH "BLACK LIGHT" GRATICULE ILLUMINATION



Fig. 1. -hp- Model 196B Oscilloscope Camera with ultra-violet lamp used to illuminate internal-graticule crt's.

The new -hp- 196B oscilloscope camera, with a low power "black light" bulb for internal graticule illumination, takes accurate photos showing improved contrast between graticule and trace while at the same time obtaining an increase in effective film speed. The near ultra-violet illumination\* causes the phosphor to glow, generating an intermediate gray background in the finished photo. The resulting photographs are far easier to read because the white trace contrasts sharply with the black graticule CRT's, greatly facilitating interpretation of the data (Fig 2).

Parallax error, observable on all photographs using the old style conventional graticule, formerly caused as much as 4% error in trace interpreta-

\*Near ultra-violet radiant energy or "black light" peaks close to the blue end of the visible spectrum in the 3500-Angstrom region. Unlike the shorter wavelengths used in germicidal lamps, near ultra-violet causes no harm to the eyes.

tion. Parallax error is eliminated when the 196B camera is used with -hp- internal graticule cathode-ray tubes<sup>1</sup>. Internal graticule crt's, standard features on many Hewlett-Packard oscilloscopes and optional on others, have black graticules built into the tube in the same plane as the phosphor. This prevents parallax which is a common problem when a separate graticule is used in front of the crt.

The UV light improves the phosphor's writing rate, resulting in an increase in effective film speed. The phosphor glow also "fogs" (sensitizes) the film while the photo is taken for increased film speed when photographing faint traces, such as repetitive traces on expanded sweep. For photographing fast, single traces, the uniformly lit phosphor is an ideal light source for presensitizing the film. The film is sensitized during a short exposure with the light on before the trace is made on a second exposure with light off. Sensitizing raises the density of the total exposure above the "toe" of the film's density/exposure curve, thus effectively increasing the film speed.

The UV lamp used in the 196B camera is a standard six inch, 4W "black light" lamp in a T-5 bulb with bases modified to fit within the camera housing. This lamp, originally designed for portable "black light" applications, causes most standard phosphors to fluoresce, including the P2, P7, P11 and P31 phosphors used in -hp- cathode-ray tubes (it will not fluoresce the older P1 phosphor). The lamp is mounted within a slotted cylinder

1. Bertrand W. Squier, Jr., "A Parallax-Free No-Glare CRT for -hp- Oscilloscopes", Hewlett-Packard Journal, Vol 12, No. 11-12, July-August 1961.

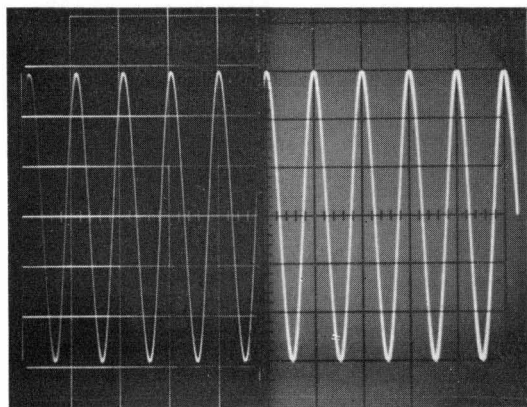

Fig. 2. Oscillogram made on special "half-and-half" showing elimination of parallax error and improved readability of internal-graticule crt.

which can be rotated to control the light intensity.

The 196B oscilloscope camera has the same design features as the widely used 196A for easy and effective oscilloscope photography. These cameras have Polaroid backs for standard  $3\frac{1}{4} \times 4\frac{1}{4}$  inch Polaroid® Land film. Both cameras use the same f/1.9 wide angle lens designed especially for oscilloscope use. Special design of this six-element, fixed focus lens insures a distortionless image, free of the barrel-lens or pincushioning effects often encountered in close-up photography.

The cameras' image ratio is 1 to 0.9 so that the 9.6 cm wide photographic image contains the full 10 cm CRT display (a 1 to 1 ratio is available on order or as a field modification).

Internal bellows allow the lens to be moved vertically through 11 detented positions so that several traces may be placed on the same photo. The bellows also prevent light leakage which, with other light seals, permits the use of the fastest film available (ASA 10,000).

A modification kit is available through -hp- Customer Field Service for converting the 196A to a 196B.

-James A. Chesebrough

### SPECIFICATIONS -hp- MODEL 196B OSCILLOSCOPE CAMERA

Lens: 3 inch (75 mm), f/1.9.  
Lens Opening: f/1.9 to f/16.  
Shutter Speeds: 1/100, 1/50, 1/25, 1/10, 1/5, 1/2, 1 sec., Time, Bulb.  
Film: Polaroid-Land film, types 42, 46, 46-L, 47, and 410.  
Dimensions: 13½ in. long, 10¼ in. high, 10 in. wide.  
Weight: Net 9 lbs.  
Price: -hp- Model 196B Oscilloscope Camera, \$490.00.  
For a 1:1 object-to-image ratio, add \$25.00.  
UV Modification Kit for 196A—\$50.00.  
Prices f.a.b. factory  
Data subject to change without notice



Fig. 3. -hp- Model 196B Camera mounted on oscilloscope.